

SPECTRUM DIGITAL, INCORPORATED			
Title OMAP5912 STARTER KIT			
Size B	Document Number 507200	Rev B	
Date: Wednesday, June 08, 2005	Sheet 2	of 13	

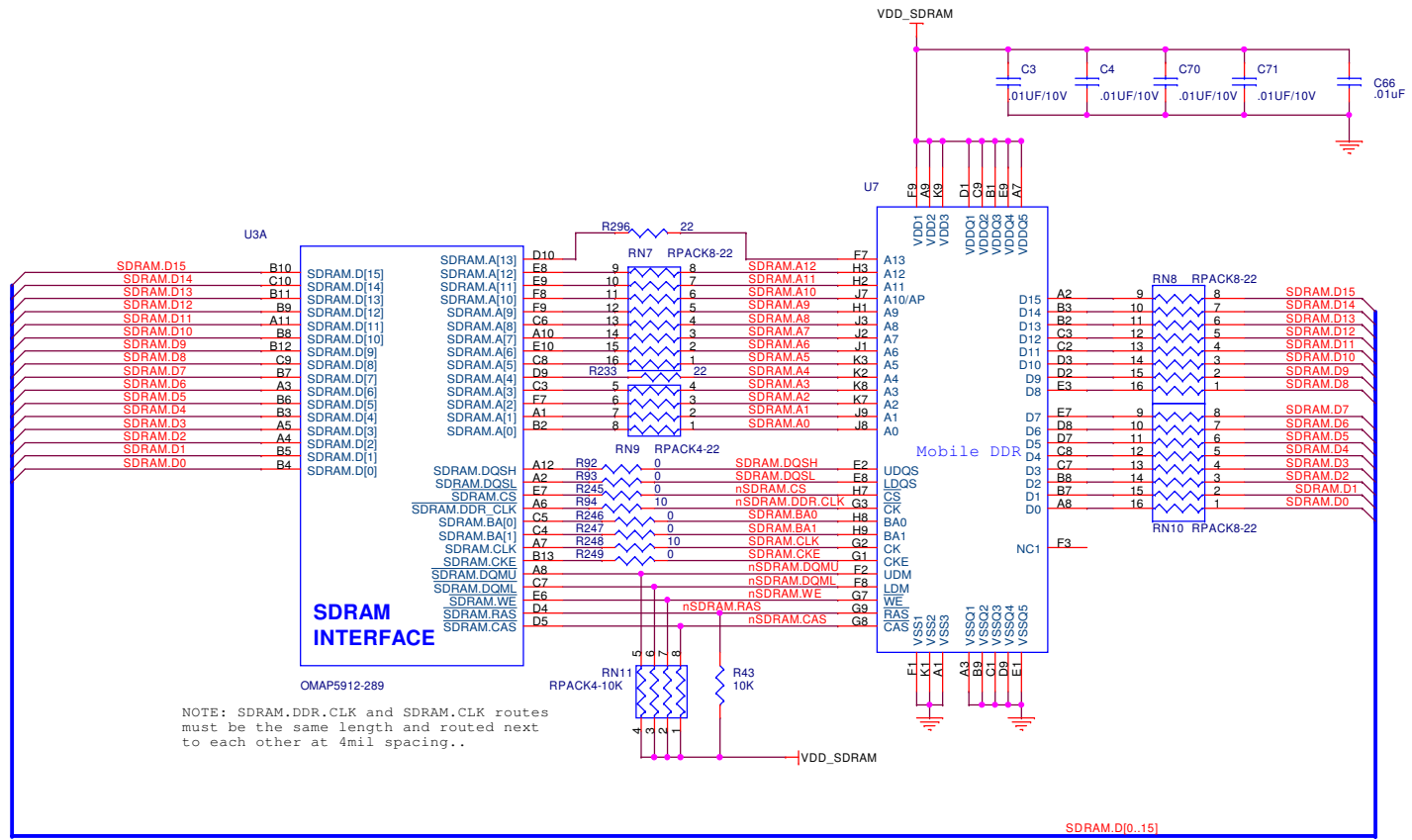

NOTE: SDRAM.DDR.CLK and SDRAM.CLK routes must be the same length and routed next to each other at 4mil spacing..

MOBILE DDR RAMS				
PART NO.	MFG.	SIZE	FREQ	PACKAGE
K4x56163DPE(L/F)C2	Samsung	16Mx16, 32MB, 256Mb	100MHZ	60 Ball BGA (6x10)
EDK2516CBBH-10E	Elipda	16Mx16, 32MB, 256Mb	100MHZ	60 Ball BGA (6x10)
K4x28163FEVG100	Samsung	8Mx16, 16MB, 128Mb	100MHZ	60 Ball BGA (6x10)

SPECTRUM DIGITAL. INCORPORATED

Title: OMAP5912 STARTER KIT

Size B	Document Number 507200	Rev B
Date: Wednesday, June 08, 2005	Sheet 3 of 13	

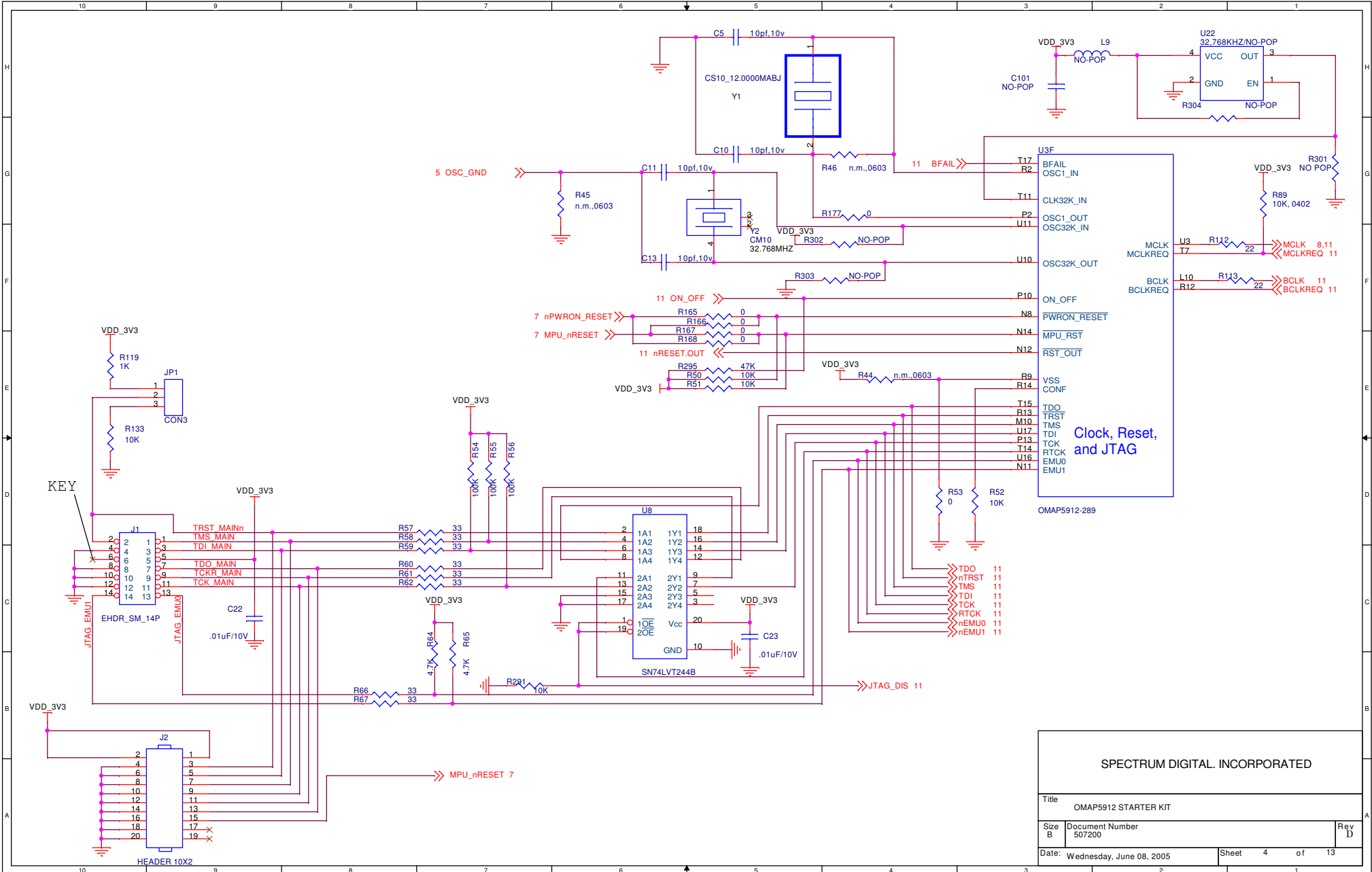

SPECTRUM DIGITAL. INCORPORATED		
Title OMAP5912 STARTER KIT		
Size B	Document Number 507200	Rev D
Date: Wednesday, June 08, 2005	Sheet 4	of 13

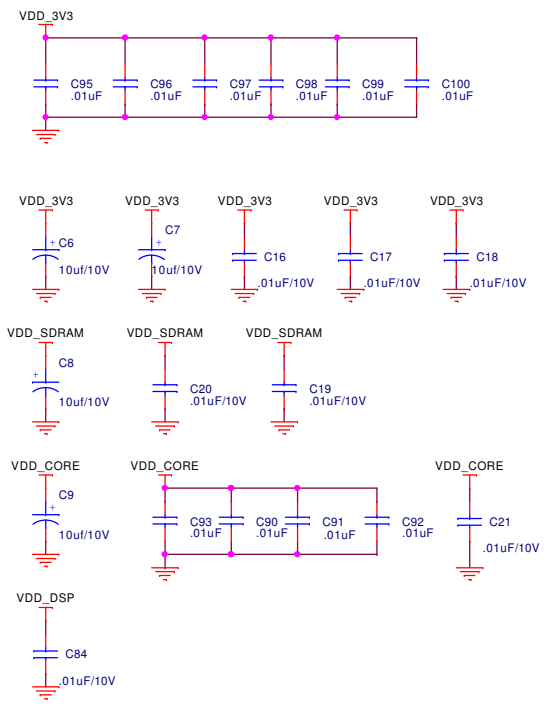
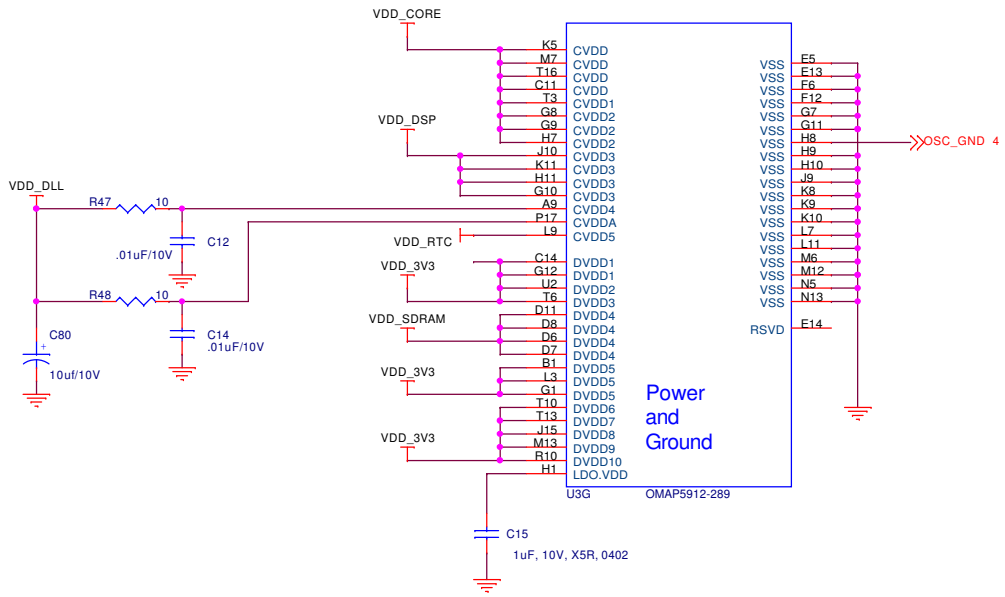

SPECTRUM DIGITAL, INCORPORATED		
Title: OMAP5912 STARTER KIT		
Size B	Document Number 507200	Rev B
Date: Wednesday, June 08, 2005	Sheet 5 of 13	

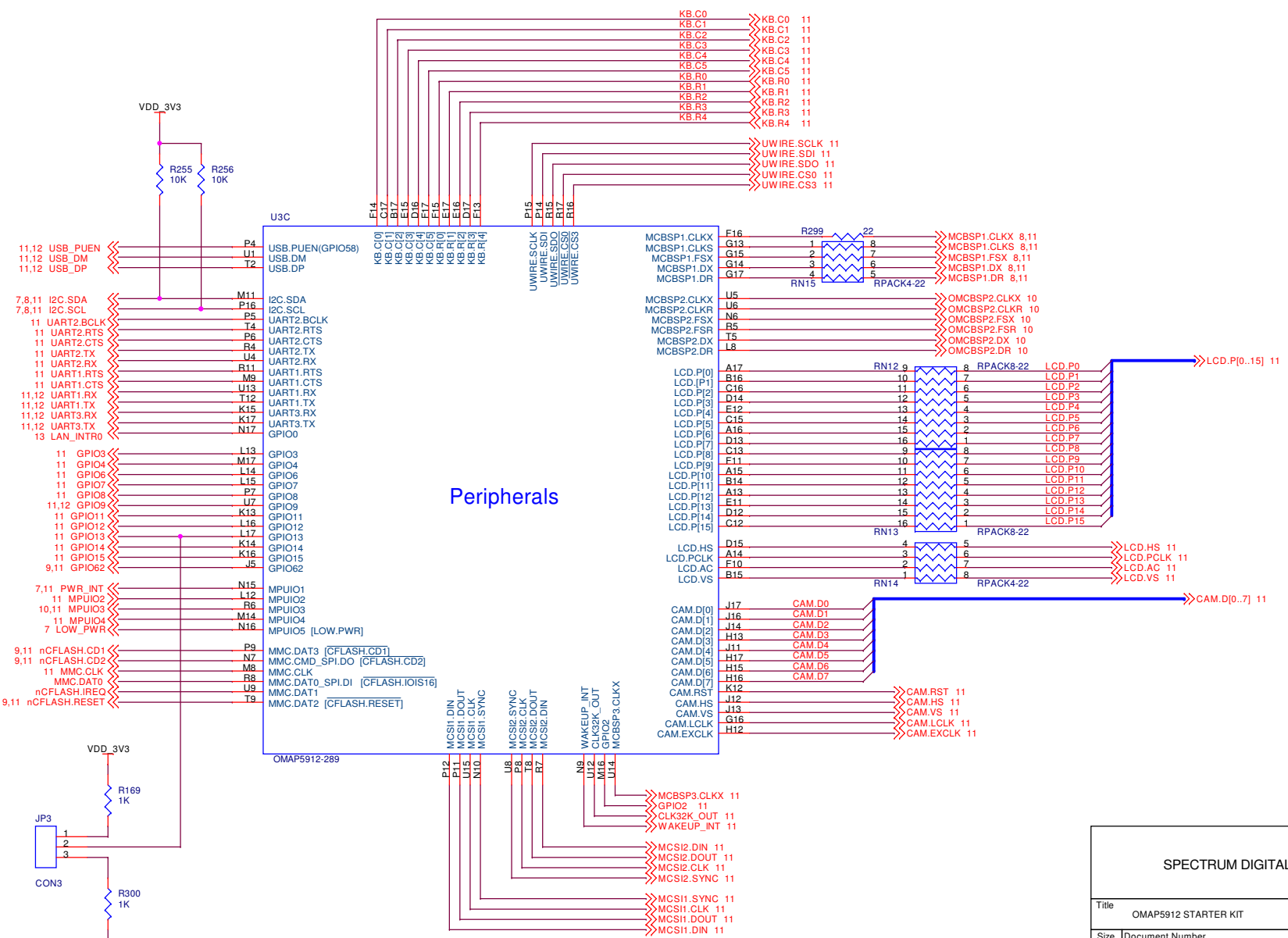

Peripherals

SPECTRUM DIGITAL, INCORPORATED			
Title OMAP5912 STARTER KIT			
Size B	Document Number 507200	Rev B	
Date: Wednesday, June 08, 2005	Sheet 6	of 13	

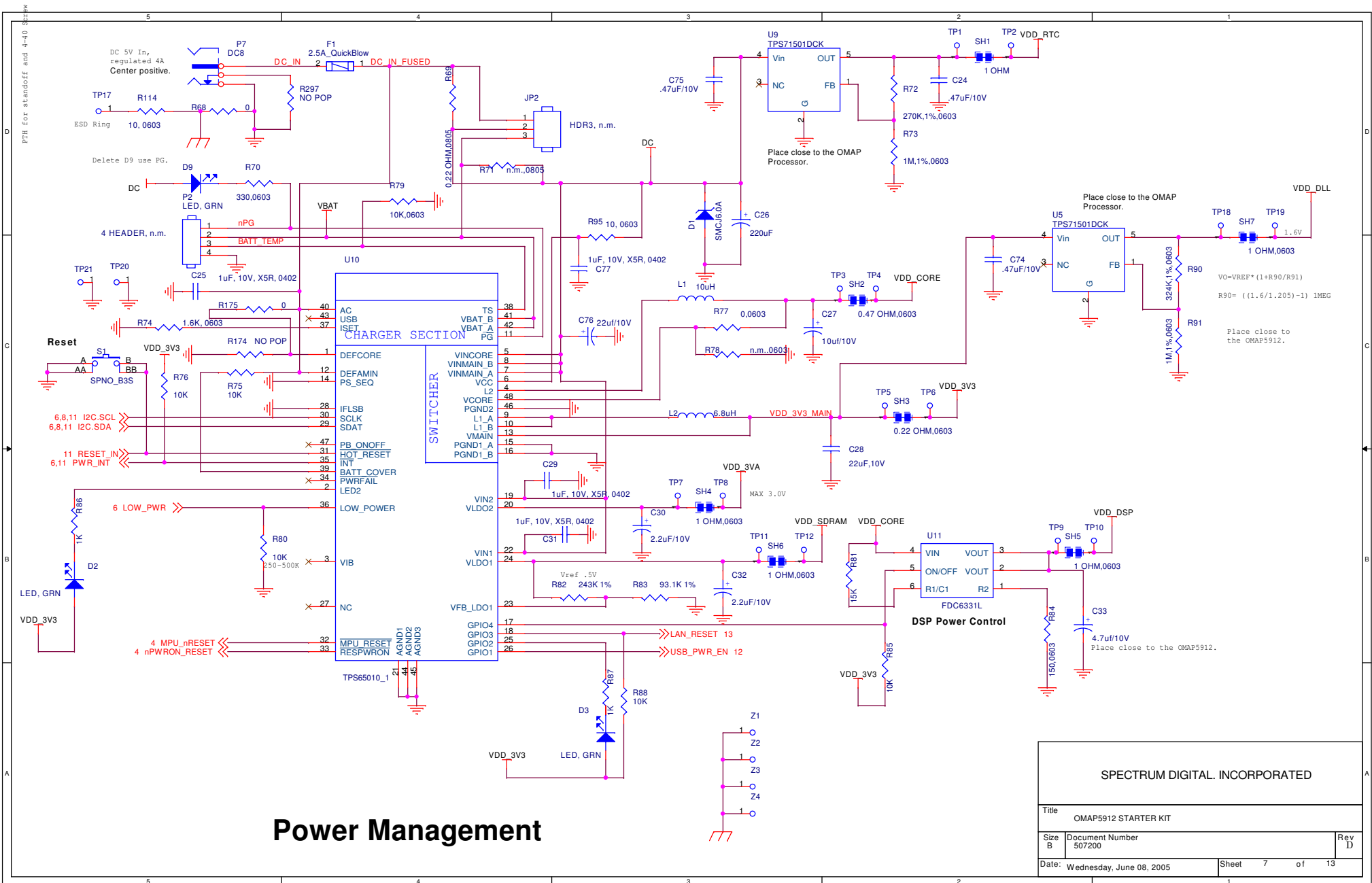

Power Management

SPECTRUM DIGITAL, INCORPORATED		
Title OMAP5912 STARTER KIT		
Size B	Document Number 507200	Rev D
Date: Wednesday, June 08, 2005	Sheet 7	of 13

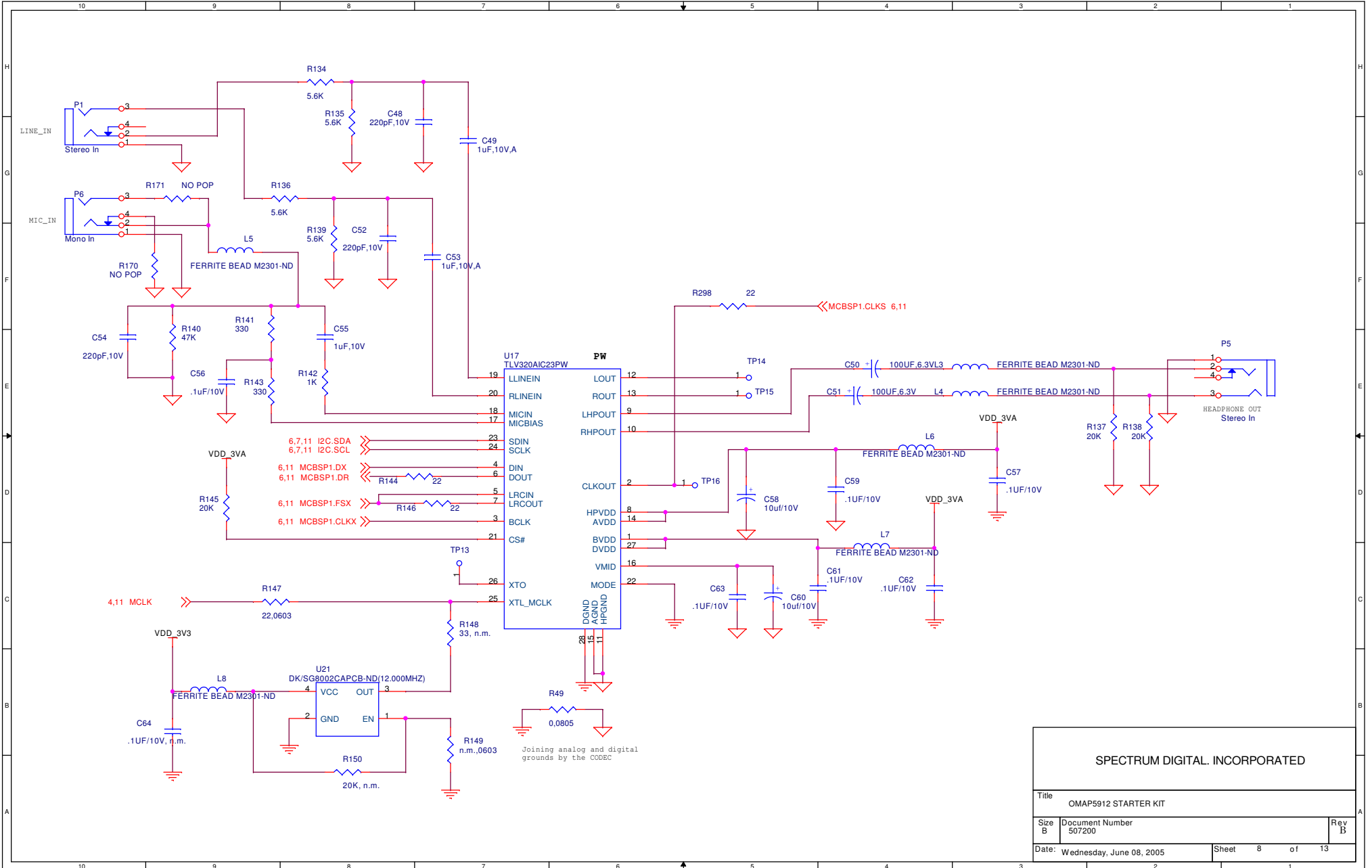

SPECTRUM DIGITAL. INCORPORATED		
Title OMAP5912 STARTER KIT		
Size B	Document Number 507200	Rev B
Date: Wednesday, June 08, 2005	Sheet 8 of 13	

Compact Flash

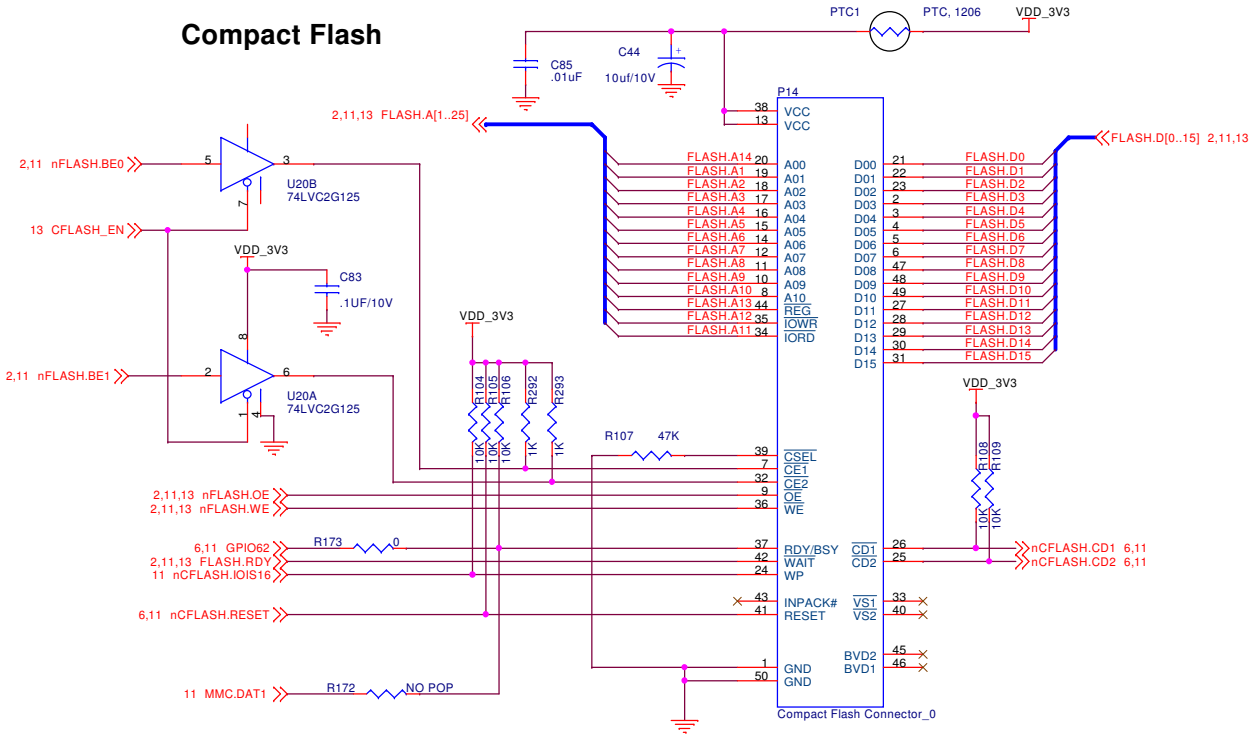

SPECTRUM DIGITAL, INCORPORATED		
Title OMAP5912 STARTER KIT		
Size B	Document Number 507200	Rev B
Date: Wednesday, June 08, 2005	Sheet 9 of 13	

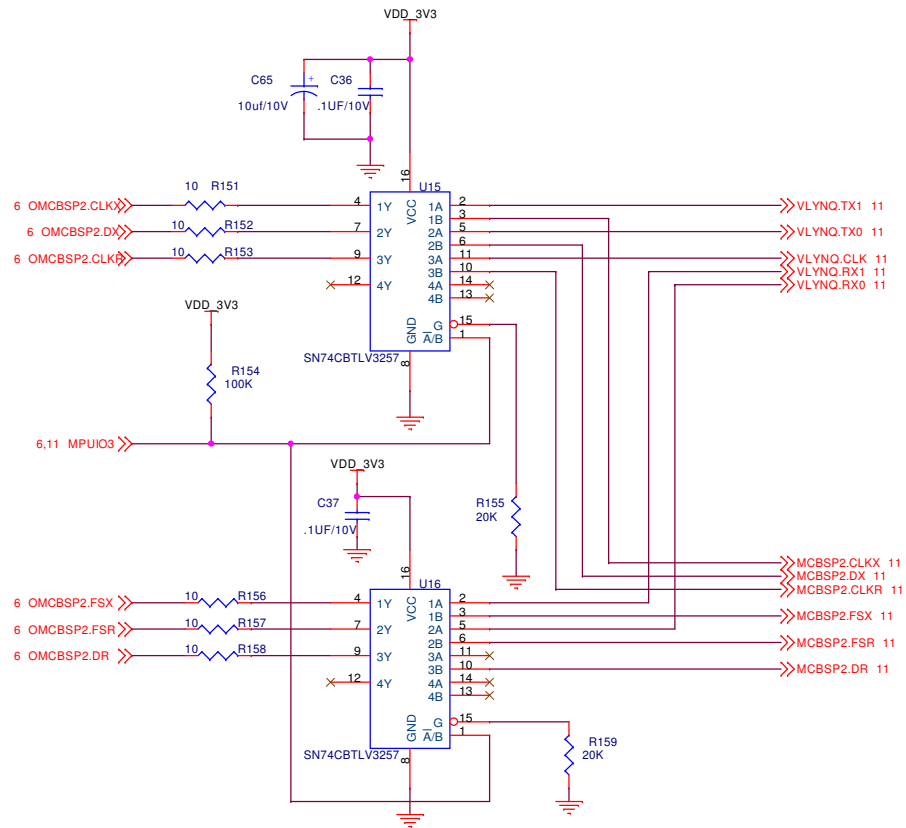

SPECTRUM DIGITAL, INCORPORATED

Title		
OMAP5912 STARTER KIT		
Size	Document Number	Rev
B	507200	B
Date:	Wednesday, June 08, 2005	Sheet 10 of 13

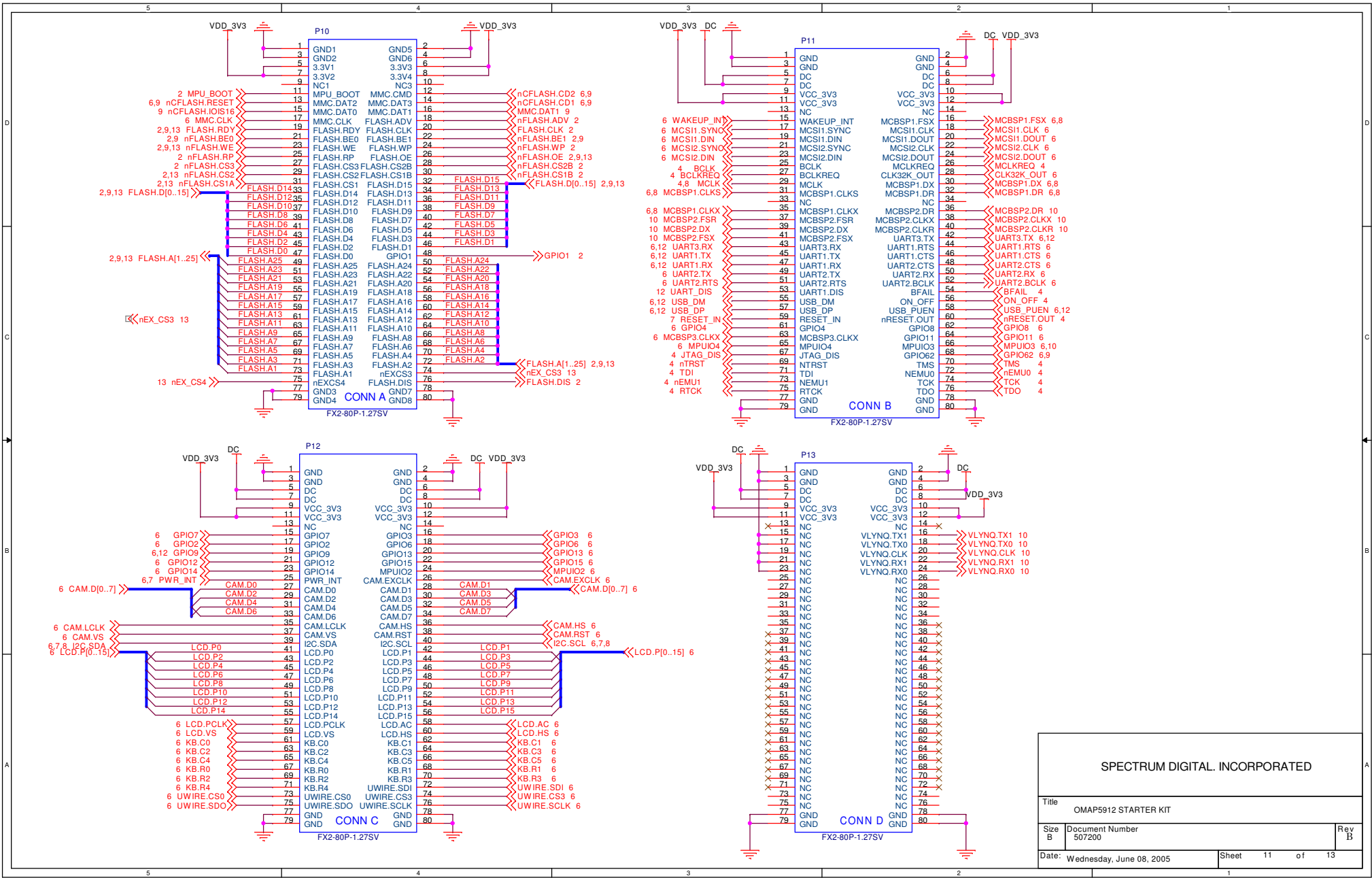

SPECTRUM DIGITAL, INCORPORATED		
Title OMAP5912 STARTER KIT		
Size B	Document Number 507200	Rev B
Date: Wednesday, June 08, 2005	Sheet 11 of 13	

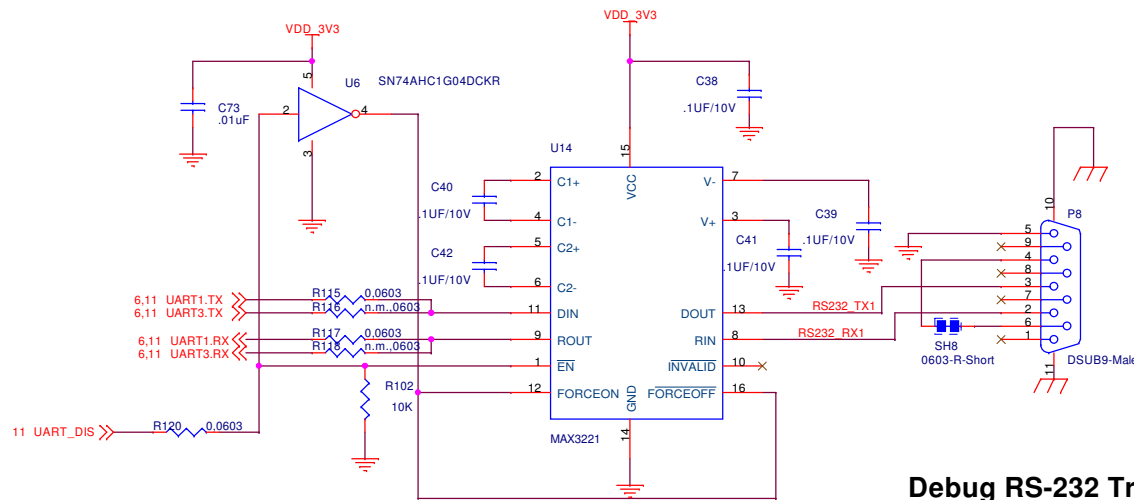

Debug RS-232 Transceiver

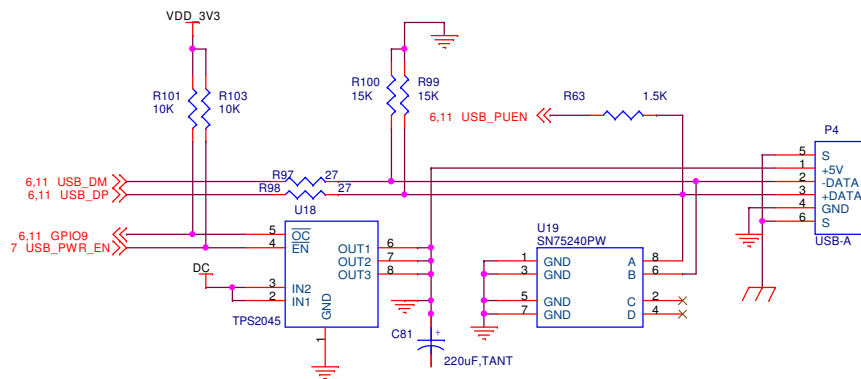

SPECTRUM DIGITAL, INCORPORATED

Title		
OMAP5912 STARTER KIT		
Size	Document Number	Rev
B	507200	B
Date:	Wednesday, June 08, 2005	Sheet 12 of 13

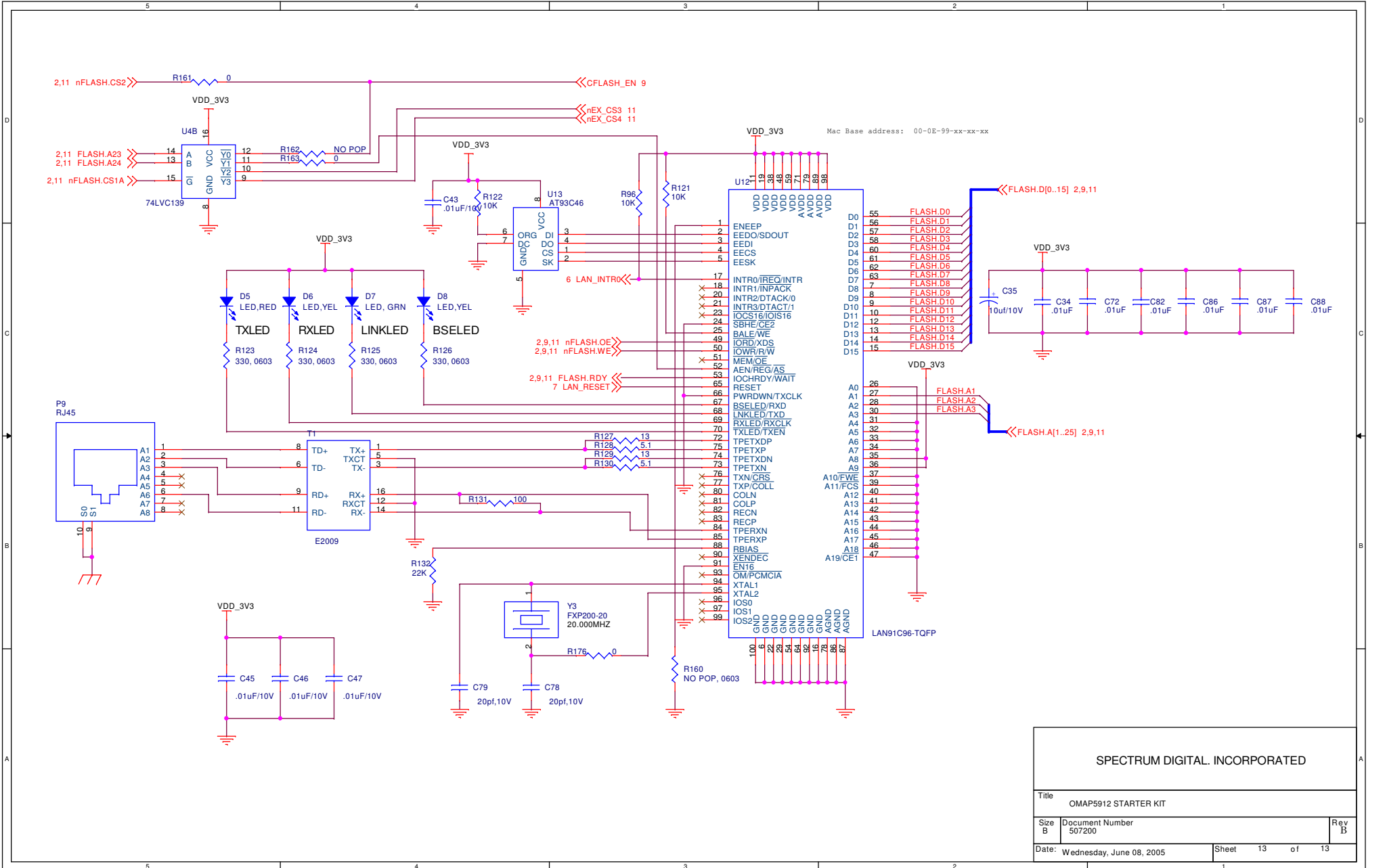

SPECTRUM DIGITAL, INCORPORATED		
Title OMAP5912 STARTER KIT		
Size B	Document Number 507200	Rev B
Date: Wednesday, June 08, 2005	Sheet 13	of 13